

CONVEY-ALL™

convey-all.com | conveyors@convey-all.com | (800) 418-9461



1665 | 1675 | 1685 SP2 BIN FILL CONVEYORS

The Convey-All™ SP2 Bin Fill Conveyors feature our redesigned mover kit for exceptional reach and performance. Convey-All conveyors are designed to be efficient and simple to use. The engine and control station are set low for easy access. The undercarriages are rugged and heavy duty, using structural steel and fabricated for bolt-together durability. Combine our Bin Fill Conveyors with a Convey-All Transfer Conveyor for ultimate efficiency.

STANDARD FEATURES:

- Collapsible hopper
- Full length windguards
- Heavy-duty scissor lift undercarriages
- Positive Pinch Drive Box
- Powder Coat Finish
- 16" Chevron Belt
- 10" Tube

10" Tube
16" Belt

UP TO
9,000BPH



SP2 CONVEYORS

Model	Under Carriage	Mover Kit	Swing Out	Axle Width	Transport Height	Transport Length	- 15° -		- 20° -		- 25° -		- 30° -	
							Discharge Height	Length	Discharge Height	Length	Discharge Height	Length	Discharge Height	Length
1665	Scissor Lift	N/A	N/A	11' 4"	12' 6"	60' 8"	13' 5"	5' 2"	18' 4"	54'	23' 2"	52' 5"	27' 9"	50' 6"
1675	Scissor Lift	AVAIL	AVAIL	11' 4"	11' 10"	75' 11"	17' 4"	69' 8"	23' 6"	68' 1"	29' 6"	66' 1"	35' 3"	63' 6"
1685	Scissor Lift	AVAIL	AVAIL	11' 4"	12' 5"	80' 11"	18' 7"	74' 6"	25' 2"	72' 10"	31' 7"	70' 7"	37' 9"	67' 10"



COOL FEATURE X

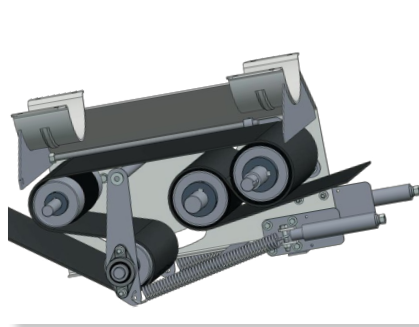

POSITIVE PINCH DRIVE BOX



This Drive Box features the Sliding Pinch Roller. It maintains positive pressure on the Drive Roller. As more product is loaded, the Pinch Roller automatically increases its pressure on the Drive Roller.

CONVEY-ALL™

DURABLE. FUNCTIONAL. **RELIABLE.**

convey-all.com | conveyors@convey-all.com | (800) 418-9461